

1830 E



www.ommelift.dk

ARTICULATED PLATFORM MOUNTED ON TRAILER

OMMELIFT



Quality since 1906

OMME LIFT A/S – Lægårdsvej 4 – DK 7260 Sdr. Omme
Phone: + 45 753 413 00 – Fax: + 45 753 415 92
E-mail: omme@ommelift.dk – Web: www.ommelift.dk

1830 E

Mounted on trailer

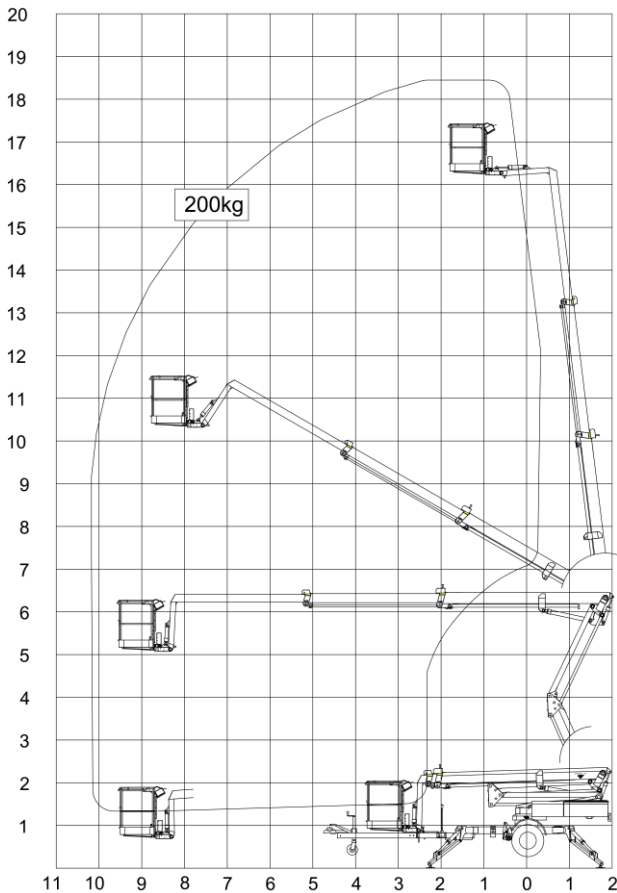

Technical data:	1830 EX	1830 EXB
Max. working height	18.30 m	
Max. outreach	10.15 m	
Max. basket load	200 kg	
Basket size	1.25x0.8x1.1m	
Turnable basket	± 41°	
Rotation	± 400°	
Power supply	230V/16A	24V/200Ah/5h
Charger	24 V/30 A	
Transport length	6.70 m	
Transport height	1.99 m	
Transport width	1.60 m	
Operational width	4.21 m	
Total weight	2450 kg	2550 kg
Controls	Proportional	
Hydraulic stabilizers	+	
Hydraulic propulsion	+	
230 V outlet in basket	+	

+ Standard

LARGE GROUND CLEARANCE



Angle boom



Propulsion



Easy control



Transport

- 1830 EX is powered by an electric motor, connected to 230 V mains and is especially suitable where continuous operation is required. 1830 EXB is powered by a heavy duty battery pack, in total 24V/200 Ah/5h. Operation is possible independently of 230 V mains connection.
- The low centre of gravity provides a secure transport after the towing vehicle.
- The 1830 E platforms are mounted with hydraulic propulsion, turnable basket and hydraulic stabilizers. When equipped with hydraulic propulsion the platform can propel itself around the work site. Operation from a special platform, giving a complete overview. The turnable basket makes it possible for 2 persons to operate parallel with e.g. a façade.
- The 1830 E platforms are equipped with an unfolding scissor system, giving the lift an increased up and over outreach over high obstacles. When operating the scissor system up and down the basket will follow a vertical line. Furthermore the lift has no tail swing at rotation. Electric wiring to the basket is protected inside the telescopic boom. The telescopic cylinder is protected under the boom.
- The 1830 E platforms are fitted with straightforward control, in the basket and at ground level. The hydraulic levers for the stabilizers are placed centrally on the chassis. The proportional controls ensure steady and smooth movements. The basket load of 200 kg applies in the complete working envelope.